



Assembly and operating Instructions

Flap-type Flow Meter

KFS

KFS-RK1, KFS-RK2

KFS-IK1, KFS-IK2

KFS-IKS1, KFS-IKS2

KFS-EM, KFS EMZ

KFS Ex

KFS-IK1 Ex, KFS-IK2 Ex

KFS-EM Ex, KFS EMZ Ex

**For use of the KFS device in hazardous areas, refer to the
"Supplementary installation and operating instructions - flap-type
flow meter KFS ... Ex"!**



Contents

1	General.....	4
1.1	Foreword	4
1.2	Exemption from liability.....	4
2	Safety	4
2.1	Symbol and meaning	4
2.2	General safety directions.....	4
2.3	Intended use.....	5
2.4	Information for Operator and operating personnel	5
2.5	Regulations and directives	5
2.6	Compliance with the IP degree of protection.....	5
2.7	Note for the use of equipment in Ex-proof version	6
2.8	Notice as required by the hazardous materials directive.....	6
3	Transport and storage	6
4	Measuring principle of the flap-type flow meter.....	6
5	Installation, start-up and maintenance of the mechanical part	7
5.1	Preparatory work	7
5.2	Installation of the KFS	7
5.3	Start-up.....	8
5.4	Maintenance	8
5.4.1	Compliance with IP protection - KFS with standard indicator part.....	10
5.4.2	Setting the reference point - KFS with standard indicator part.....	10
5.4.3	Replacement of scale - KFS with standard indicator part.....	10
5.4.4	Setting the pointer reference point - KFS-EM.....	11
5.4.5	Replacement of scale - KFS-EM	11
5.4.6	Removal of the EM-indicator part from the pressurized measuring point	11
6	Installation, start-up and maintenance of devices with electrical add-on equipment	12
6.1	Preparatory work for installation and maintenance	12
6.2	Devices with standard indicator casing	12
6.2.1	Cabling of the contacts	12
6.2.2	Setting the switching points	13
6.2.3	KFS-RK1, KFS-RK2	13
6.2.4	KFS-IK1 , KFS-IK2	14
6.2.5	KFS-IK1 with ATEX approval.....	16
6.2.6	KFS-IKS1, KFS-IKS2.....	17
6.3	The indicator part M40.....	18
6.3.1	Versions.....	18
6.3.2	Electrical signal output KFS-EM	18
6.3.3	Compliance with IP-degree of protection.....	19
6.4	Electrical connection KFS-EM	20



6.4.1	HART® communication with ESK4	22
6.4.2	ESK4 - Loop Check Mode	23
6.4.3	Technical Data EM.....	24
6.5	Plug-in contact unit IK1, IK2, IKS1, IKS2.....	25
6.5.1	Electrical connection.....	25
6.5.2	Setting the limit value	27
6.5.3	Switching contact definition	27
6.5.4	Definition MINMIN - MAXMAX.....	27
6.5.5	Technical Data	28
6.5.6	Electrical data hazardous area	28
6.6	Replacement - Retrofitting an ESK4 and its calibration.....	29
6.7	Retrofitting a second limit value switch.....	30
6.8	Flow Totalizer KFS-EMZ.....	30
6.9	Component overview for electrical Retrofit.....	32
7	Service.....	33
8	Disposal.....	33
9	Remaining risks	33
10	Technical Data	34
10.1	General technical data.....	34
10.2	Materials	35
10.3	Measuring ranges H ₂ O	36
10.4	Measuring ranges air.....	37
10.5	Dimensions and weights.....	37
10.6	M12 Right angle plug.....	39
11	Spare parts, accessories	40
11.1	KFS with standard indicator part and limit value switches.....	40
11.2	KFS-EM	42
11.3	Assembly aid KFS-M40/EM (optional).....	43



1 General

1.1 Foreword

These Installation and Operating Instructions are applicable to devices of Series KFS. Please follow all instructions and information given for installation, operation, inspection and maintenance. The Instructions form a component part of the device, and should be kept in an appropriate place accessible to the personnel in the vicinity of the location. Where various plant components are operated together, the operating instructions pertaining to the other devices should also be observed.

1.2 Exemption from liability

Kirchner und Tochter accepts no liability for any damage or interruptions of operation resulting from human error, failure to comply with these installation and operating instructions, improper performance of installation and repair work, use of spare parts other than those from the original manufacturers or use of the KFS devices other than for the intended purpose.

2 Safety

2.1 Symbol and meaning

 Safety notice

This symbol is placed against all directions/information relating to occupational health and safety in these Installation and Operating Instructions and draws attention to danger to life and limb. Such notices should be strictly observed.

2.2 General safety directions

These Installation and Operating Instructions contain basic instructions for the installation, operation, inspection and maintenance of the flow meter. Failure to comply with these Instructions or improperly executed installation, wiring and repair work can lead to serious faults in the plant, giving rise to hazardous situations for "man and beast" as well as damage to property.

The operator is required to rule out potentially hazardous situations through voltage and released media energy.



2.3 Intended use

The KFS devices are designed and intended for measuring the flow of liquids and gases. They may only be installed between flanges in the pipeline. Select the KFS device model on the basis of the nominal diameter and nominal pressure at the site and also the kind of fluid product concerned; limit values are specified in the sect. 10 "Technical data" and should not be exceeded. Only devices that bear the "Ex" marking may be operated in hazardous areas.

2.4 Information for Operator and operating personnel

Authorized installation, operating, inspection and maintenance personnel should be suitably qualified for the jobs assigned to them and should receive appropriate training and instruction. All persons charged with assembly, mounting, operation, inspection and maintenance duties must have read and understood the operating instructions. Gaskets in contact with the fluid product must be replaced after all maintenance and repair work.

2.5 Regulations and directives



In addition to the regulations mentioned below, pay attention without fail to the notices given in sect. 2.7 for operation in hazardous areas!

All relevant regulations should be observed in respect of flow meter operation. These include in particular:

- Regulation concerning explosion protection (11. ProdSV, 2014/34/EU)
- Regulation concerning safe working conditions (BetrSichV , 2009/104/EG)
- If appropriate, regulation concerning hazardous materials
- Accident prevention regulations
- Pressure Equipment Directive PED (2014/68/EU)

2.6 Compliance with the IP degree of protection

Devices with standard indicator parts have IP66 degree of protection, with M40 indicator part P68 degree of protection. In the case of maintenance work involving the indicator parts, notes on maintaining the IP degree of protection are given in sect. 5.4.1, 6.1 und 6.3.3 (KFS-EM).



2.7 Note for the use of equipment in Ex-proof version

The KFS, KFS-IK1/2 and KFS-EM flow meters are certified for use in hazardous areas Zone 1 and 2, device categories 2 and 3, atmosphere Gb, according to Directive 2014/34/EU. For such use, the regulation concerning electrical and non-electrical devices in hazardous areas (Directive 2014/34/EU) is to be observed.



For use of the devices in **hazardous areas**, refer to the "Supplementary installation and operating instructions - Flap-type flow meter KFS ... Ex". Due to possible static charges, the polycarbonate enclosure of the indicator part of KFS Ex and KFS-IK1/2 Ex devices may only be cleaned with a damp cloth.

2.8 Notice as required by the hazardous materials directive

In accordance with the law concerning handling of waste (critical waste) and the hazardous materials directive (general duty to protect), we would point out that all flow meters returned to Kirchner und Tochter for repair are required to be free from any and all hazardous substances (alkaline solutions, acids, solvents, etc.).



Make sure that devices are thoroughly rinsed out to neutralize hazardous substances. Cavities in the KFS also have to be neutralized. For this purpose, open the neck of the KFS ring by dismantling the indicator (detach the flange connection between the KFS ring and the magnet casing). This includes the screws, Item 9 in the drawing in sect. 11.1 and Item 15 in the drawing in sect. 11.2).

3 Transport and storage

Always use the original packing for transport, handling and storage. Protect the device against rough handling, coarse impact, jolts etc.

4 Measuring principle of the flap-type flow meter

A half-round plate, or flap, is fastened across the direction of flow to a spring-mounted rotating spindle in a ring that is inserted between flanges in a pipeline. As the flow rate increases, the flap rotates counter to the restoring force of the spring in the direction of flow. The ensuing angle of rotation, depending on the volume rate of flow, is transmitted via a magnetic coupling to the indicator part



5 Installation, start-up and maintenance of the mechanical part

5.1 Preparatory work

Have ready flanges and fastening materials as specified in EN 1092-1 for mounting the device between flanges. Between the flanges, include a distance of ring thickness plus 4 mm for the gaskets. Refer to assembly dimensions in sect. 10.5.

Check the inside diameter of your pipeline and the gaskets. Neither should be smaller than the inside diameter of the KFS. If they are, the measuring flap will jam. Straight unimpeded pipe runs upstream and downstream of the installation location should have lengths equal to 4 - 6 times the nominal size DN.

The mounting location for control equipment should be provided downstream of the flow meter. Make sure that the flanges are in alignment and the sealing faces parallel to one another.

5.2 Installation of the KFS

- Generally comply with the maximum pressure and maximum temperature levels allowable for the KFS at the measuring point in your plant.
- The direction of flow must be the same as that indicated by the flow arrow on the device.
- Drain the pipelines before installing the device.
- Use gaskets made of rubber or SIL; for plastics devices, use only gaskets made of rubber with a Shore hardness A of approx. 65°.
- The gaskets should not project into the pipeline and the flow meter must be in line with the pipe axis, otherwise measurements would be falsified and/or the device could jam.

Incorporating the indicator part in the equipotential bonding system in hazardous areas: The indicator part must be grounded. This can be done e.g. using a wire jumper between the flange on the indicator part and a pipe flange on the main pipeline with cable lugs appropriate for the bolted connection (not included with the flow meter!).

Incorporating the indicator in the lightning protection system (if necessary). The Operator is responsible for checking and determining the scope!

Tighten threaded joints for the KFS made of PVC, PP or PVDF only with max. 75 Nm; higher torques may cause the flap spindle to jam and/or the device ring to break. The device version made of PVC, PP or PVDF is not allowed to be used in hazardous areas.



5.3 Start-up

Pressurize the measuring pipeline. Avoid water hammer or flow separation.

Check the flange connections for leak-tightness and retighten bolted connections if necessary.

Test the local indicator on the device with varying volumetric flow rates, starting with the maximum value.

5.4 Maintenance



The device is normally maintenance-free. Should it become soiled, it will need to be removed from the pipeline for cleaning. Devices fitted with contacts must be disconnected from supply and de-energized.

To dismantle the device you will need the following tools: 2x open-jawed spanner, jaw span 13 mm, 1x open-jawed spanner, jaw span 7 mm, 1x screwdriver 4x 0.6 mm, 1x socket spanner, size 7 mm, up to DN 100, or 1x socket spanner, size 8 mm, up to DN 250, or 1x socket spanner, size 10 mm, for DN 300 and higher. Required spares: 2x gasket. After dismantling, check all parts for signs of damage, corrosion, wear, etc., and replace if necessary!

- If necessary, wear personal protective gear (safety goggles, protective gloves, conductive footwear).



- Depressurize the pipe.
- Caution: Slacken screws/bolts only when the system has been de-energized, the pipe depressurized and free of fluid product.
- Drain the pipes.
- Remove the device from the pipeline in the reverse order as described in sect. 5.2 .
- Detach the dial gauge with magnet casing from the neck of the device by removing the four M8 screws (Item 9 or 15).
- Unscrew the fastening screws (Item 17) between spindle and flap (Item 18).
- Pull the spindle together with the magnet casing and the spring assembly (Item 13) out of the device.
- Clean all mechanical parts with appropriate cleaning agents. If necessary, clean the indicator part with a damp cloth that has been rinsed in soap suds and wrung out. Reassemble in the reverse order, paying special attention to the position of the flap.
- The bearing marked with a centre punch must point towards the spring.

For Item numbers, refer to drawings in sect. 11.1



KFS

Flap-type flow meters



Do not change the original orientation of the flap (maintaining the direction of rotation appropriate to the indicator part). The flap requires a minimum of 1 mm clearance on both sides (risk of jamming and sparking).



Hazardous areas: Do not on any account remove the labelling on the scale casing containing information on explosion protection.



Before switching on the supply voltage again, make sure that all parts are completely dry and have been connected up in accordance with regulations. Protect the devices from excessive dirt and extreme variations in ambient temperature.



In connection with all maintenance, assembly and repair work of the flow meters, make absolutely sure that a potentially explosive atmosphere cannot occur.



5.4.1 Compliance with IP protection - KFS with standard indicator part



When carrying out assembly work on the indicators (KFS, KFS-IK1, KFS-IK2, KFS-IKS1, KFS-IKS2, KFS-RK1, KFS-RK2), and to comply with the IP degree of protection, you should wear rubber gloves or similar expedient in order to obtain a maximum torque when tightening the bayonet joint. (Optional installation aid, see sect. 11.3)

5.4.2 Setting the reference point - KFS with standard indicator part

If, when flow is switched off, the pointer in the indicator part should not be located at the reference point, correct the reference point setting. Make all adjustments only after the flow has been switched off.

You will need the following tools: open-jawed spanner, jaw span 7mm, screwdriver 4x 0.6 mm.

- Detach the bayonet ring (Item 1) from the gauge casing and remove it together with the seal (Item 3) and perspex disc (Item 2).
- Lock the pointer spindle using the 7 mm open-jawed spanner, unscrew the fastening screw (Item 4) and reset the pointer to the reference point.
- Reassemble the indicator in reverse order.

5.4.3 Replacement of scale - KFS with standard indicator part

You will need the following tools: open-jawed spanner, jaw span 7 mm, screwdriver 4x 0.6 mm, socket spanner, span 5.5 mm; if necessary, 1 spring washer (Item 5).

- Detach the bayonet ring (Item 1) from the pressure gauge casing and remove it together with the seal (Item 3) and the perspex disc (Item 2).
- Lock the pointer spindle using the 7 mm open-jawed spanner, and unscrew the fastening screw (Item 4) and the spring washer (Item 5).
- Remove the pointer (Item 6).
- Unscrew the three cap nuts (Item 7) and remove the scale (Item 12) from the casing.
- To fit the new scale, proceed in the reverse order.

For Item numbers, refer to drawings in sect. 11.1



5.4.4 Setting the pointer reference point - KFS-EM

Tools needed: 1x flat-tip screwdriver

- Loosen the housing cover by turning it counter-clockwise and then remove it.
- With the flat-tip screwdriver, hold the pointer spindle in the resting position of the indicator part use your other hand to move the pointer against the frictional force of the pointer-fastening to the point on the scale marked "Rp".
- Put back on the housing cover and fasten it in a clockwise direction. (See sect. 5.4.1).

5.4.5 Replacement of scale - KFS-EM

- Loosen the housing cover by turning it counter-clockwise and then remove it.
- The scale is located in two slots in the surrounding casing. Pull the scale sideways out of these slots in the direction of the pointer.
- Insert the new scale.
- Put back on the housing cover and fasten it in a clockwise direction. (See sect. 5.4.1).

5.4.6 Removal of the EM-indicator part from the pressurized measuring point

Detach the indicator part at the two brackets on the outside of the indicator casing (see note in sect. 11.2).



6 Installation, start-up and maintenance of devices with electrical add-on equipment

The installation, commissioning and maintenance of the mechanical part, see sect. 5

Installation and wiring work may only be carried out by qualified electricians. In hazardous areas the following installation standards must be observed:

EN 60079-14 EN 60079-17

6.1 Preparatory work for installation and maintenance

For connecting the contacts, have ready flat-tip and crosshead screwdrivers as well as tools for stripping the cables and cutting them to size. In line with the electrical specifications of your device, you also need cable material for the connection. To maintain the IP degree of protection, only cables with outside diameters of 4.5 mm - 7 mm may be used in connection with the right-angle plug (sect. 10.6) at the standard indicators with contacts (KFS-IK1...). The cable specifications for the KFS-EM device are given in sect. 6.3.3 for indicator part EM.

6.2 Devices with standard indicator casing

This includes the following devices: KFS-IK1, KFS-IK1 Ex, KFS-IK2, KFS-IK2 Ex, KFS-IKS1, KFS-IKS2, KFS-RK1 and KFS-RK2. The indicator part casing consists of a tall Polycarbonate cover, a bayonet ring, a corresponding casing and a gasket (note: IP degree of protection! Refer to sect. 5.4.1). Only the KFS-IK1 Ex and KFS-IK2 Ex devices may be used in hazardous areas.

6.2.1 Cabling of the contacts

- Disconnect the cable from the mains.
- Remove the right-angle plug from the rear panel of the indicator.
- Take the plug out of the connector housing and detach the PG screwed cable gland elements.
- Slide the individual parts of the PG screwed cable gland and the housing of the right-angle plug over the cable.
- Strip the insulation from the wires and connect these to the right-angle plug according to the terminal diagrams in the following sections.
- Remount the right-angle plug in the casing and tighten down the PG screwed cable gland.
- Re-Connect to mains.



6.2.2 Setting the switching points

The contact switching points are easy to adjust after removing the perspex hood. Use a finger to move the setpoint pointer of the switch to the appropriate point on the scale. Then check the switching point by moving the pointer beyond the set switching point.

6.2.3 KFS-RK1, KFS-RK2

The series RK signal transmitters are mechanically operating, floating reed contacts.

We advise using switch protection relays of the MSR series to increase the switching capacity and reduce the capacitive load. These are available in various versions in terms of voltage supply, sensor output and number of outputs.

RK1	Version with one switch
RK2	Version with two switches
Switch	Reed switch, floating
Switching function	NC or NO
Switching performance	bistable
Proof voltage	max. 140 V AC/200 V DC
Switching voltage	50 V AC/75 V DC
Current switched	max. 0,25 A
Switch rating	max. 5 VA/3 W
Ambient temperature	-25 ... +105 °C

Above 50 V AC / 75 V DC, contacts are subject to the EU Low Voltage Directive. The user has to verify their use.

Terminal assignment
Contact RK-1

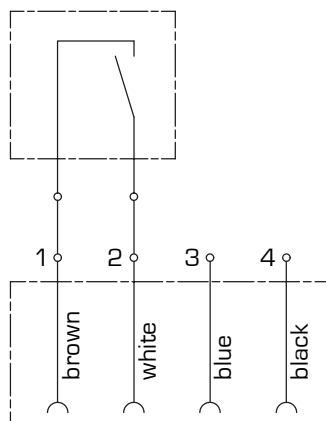

Terminal assignment
Contact RK-2

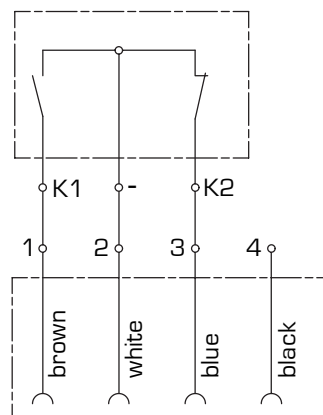

Terminal assignment
at right angle plug

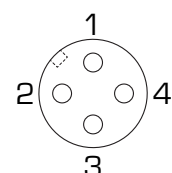



6.2.4 KFS-IK1 , KFS-IK2

Series IK built-in electrical signal transmitters are non-contacting, inductive make and break contacts which operate when a control vane moved by the setpoint pointer dips into and out of the slot initiator. The change in signal is used for driving a control device via an isolation switching amplifier.

IK1	Version with one inductive limit switch
IK2	Version with two inductive limit switches
Switch data	
Function	Inductive slot initiator acc. to NAMUR DIN 19233, two-wire
Switching function	NC or NO
Slot width	2,0 mm
Hysteresis	1,0 % v. E ... 10 % v.E
Repeat accuracy	≤ 2,0 %
Temperature drift	≤ ± 10 %
Ambient temperature	-25 ... +70° C
Voltage	nom. 8,2 V DC
Switching frequency	≤ 2,5 kHz
Switching performance	bistable
Nominal Voltage	8 V DC via isolation switching amplifier
Power consumption	
Active area uncovered	≥ 2,1 mA
Active area covered	≤ 1,2 mA
Ambient temperature	-25 ... +70 °C
Polarity reversal protection	yes
Certification to	KEMA 01 ATEX 1264X
Inner inductance (L _i) / capacitance (C _i)	266 μH/41 nF * Values for pre-assembled cables up to 10 m
Labelling of slot initiator	Ⓔ II 1 G Ex ia IIC T6 Ga/ II 1 D Ex ia IIIC T95 °C Da (max. U _i = 20 V, I _i = 60 mA, P _i = 130 mW)



KFS

Flap-type flow meters

Terminal assignment
Contact IK-1

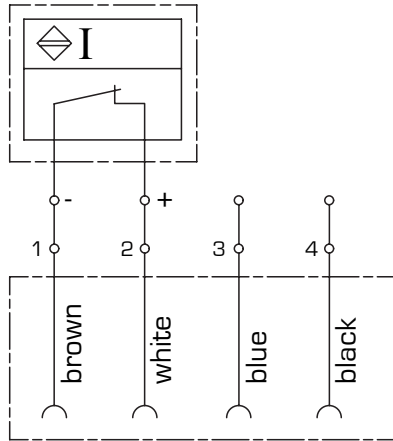

Terminal assignment
Contact IK-2

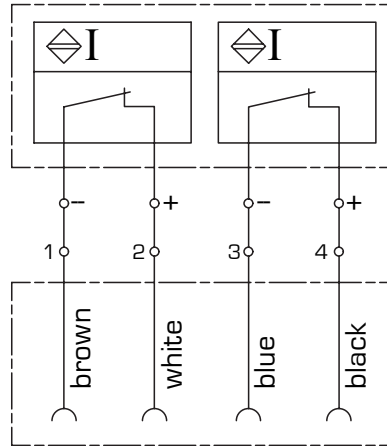

Terminal assignment
at right angle plug

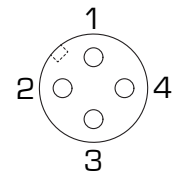



6.2.5 KFS-IK1 with ATEX approval

The Operator is required, as a matter of principle, to take note of the details given in the type examination certificate (*TÜV 15 ATEX 7805 X*). The contact IK Ex operates on the same principle as the above-mentioned in sect. 6.2.4. Devices with this contact satisfy the requirements of Directive 2014/34/EU (ATEX) and are permitted to be operated in Zone 1 hazardous areas, provided they are fed from a certified and matched intrinsically safe circuit. The allowable electrical connection data and maximum allowable ambient temperatures for operation in hazardous areas are contained in the EU-type examination certificates for Category 2G Ex ia IIC T6...T1 Gb. For use in hazardous areas, the following measures must be taken:

The indicator part must be grounded. This can be done, e.g. by using a wire jumper between the flange on the indicator part and a pipe flange on the main pipeline with cable lugs appropriate for the bolted connection (not included with the flow meter!).

Use isolation switching amplifiers with appropriate type test certificates to ATEX. Suitable switching amplifiers are:

- KFA6-SR2-Ex1.W, supply power 230 VAC
- KFA5-SR2-Ex1.W, supply power 115 VAC
- KFD2-SR2-Ex1.W, supply power 24 VDC

The bolted connections of the flanges between indicator part and flap must feature tooth lock washers on both sides. These are already mounted on delivery.

The devices approved for hazardous duty feature a blue PG screwed gland at the right-angle plug for the indicator part, with integrated strain relief device.

In addition, a sticker is located on the indicator with information on how to avoid electrostatic charges.

Please note the information from the "Supplementary Installation and Operating Instructions - Flap-type flow meter KFS ... Ex".

Allowable media temperatures:



-20°C ... +70°C without additional insulation measures
-70°C ... +200°C when Operator has insulated measuring part and pipe to prevent heat up of indicator part and el. components



6.2.6 KFS-IKS1, KFS-IKS2

Built-in electrical signal transmitters of the IKS series are non-contacting make and break contacts which operate when a control vane actuated by the setpoint pointer dips into and out of the slot initiator. The signal change can be processed directly in a PLC system.

IKS1	version with one switch
IKS2	version with two switches
Switch	inductive slot initiator
Switching function	NC or NO
Switching performance	bistable
Supply voltage	24 V DC
Current switched I_A	≤ 100 mA
Open-circuit power consumption	≤ 10 mA
Ambient temperature	-25 ... +70° C
Explosion protection	no
Voltage drop (at I_{max})	$\leq 1,2$ V

Given PNP-switching devices, the switched output 3 forms a connection to 2 (+). Between 3 and 1 a load R_L must be selected so that the max. current switched (100 mA) is not exceeded. For two contacts, this applies analogously to a load R_L between 1 and 4 (no direct connection between 1 and 3, or 1 and 4).

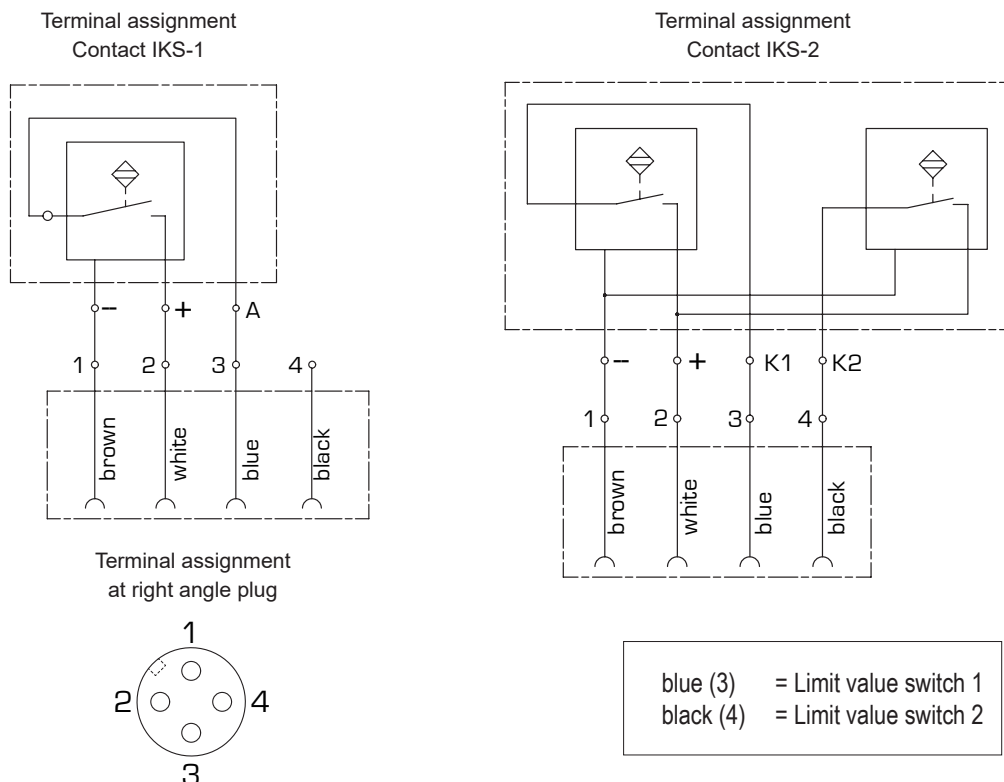



6.3 The indicator part M40

6.3.1 Versions

KFS-M40	local mechanical indicator
KFS-M40-IK1	with one inductive limit value switch
KFS-M40-IK2	with two inductive limit value switches
KFS-M40-IKS1	with one electronic limit value switch
KFS-M40-IKS2	with two electronic limit value switches
KFS-EM	with 4 ... 20 mA output
KFS-EM-IK1	with 4 ... 20 mA output & one inductive limit value switch
KFS-EM-IK2	with 4 ... 20 mA output & two inductive limit value switches
KFS-EM-IKS1	with 4 ... 20 mA output & one electronic limit value switch
KFS-EM-IKS2	with 4 ... 20 mA output & two electronic limit value switches
KFS-EMZ	with 4 ... 20 mA output, totalizer & LC-Display
KFS-M40-IK1 Ex	with one inductive limit value switch, explosion-proof design
KFS-M40-IK2 Ex	with two inductive limit value switches, explosion-proof design
KFS-EM Ex	with 4 ... 20 mA output, explosion-proof design
KFS-EM-IK1 Ex	with 4 ... 20 mA output & one inductive limit value switch, explosion-proof design
KFS-EM-IK2 Ex	with 4 ... 20 mA output & two inductive limit value switches, explosion-proof design
KFS-EMZ Ex	with 4 ... 20 mA output, totalizer & LC-Display, explosion-proof design



Note: For use in hazardous areas, please refer to the "Supplementary Installation and Operating Instructions - Flap-type flow meter KFS ... Ex".

6.3.2 Electrical signal output KFS-EM

The M40 indicator part of the KFS-EM with the ESK4 module supplies a current of 4 ... 20 mA in two-wire connection that is proportional to the current flow rate. Transmission is force-free and hysteresis-free. The ESK4 has been factory-calibrated relative to the flow measuring range. The calibration values, used for linearization of the indicator, are stored in a memory chip (EEPROM). In such cases a protected extra-low voltage (PELV) is recommended.

All instruments connected to the measuring circuit (indicators, recorders) are connected in series and together may not exceed the maximum external resistance (see data pertaining to electrical signal output). The ESK4 has polarity reversal protection.



6.3.3 Compliance with IP-degree of protection

The measuring device meets all requirements of protection category IP66/68.

Therefore it is essential to observe the following points:

- Use only original gaskets. They must be clean and free of any damage. Defective gaskets must be replaced.
- The electrical cables must be undamaged and must comply with regulations.
- The cables must be laid with a loop ③ upstream of the measuring device to prevent water from getting into the housing.
- The cable feedthroughs ② must be tightened.
- Close the unused cable feedthroughs using blanking plugs ①.
- Do not kink lines at the cable gland.
- The supplied cables may not be mechanically stressed.

- ① Use blanking plugs if no cable is routed through
- ② Tighten cable feedthrough firmly
- ③ Lay the cable in a loop

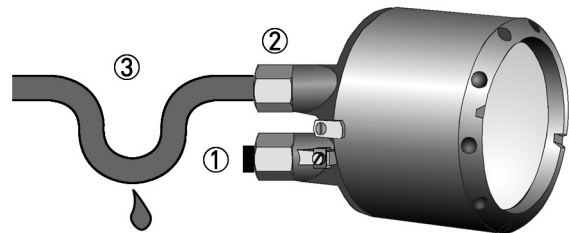

Thread	Material	Cable diameter	Protection	Comment
M 20x1,5	PA	8 - 13 mm	IP 68 - 5 bar	Standard
M 20x1,5	brass, nickel plated	10 - 14 mm	IP 68 - 10 bar	

Please note that the cable glands must at least have a degree of protection of IP68!



6.4 Electrical connection KFS-EM

The plug-in type connection terminals of the ESK4 module in the M40 indicator part can be removed to connect the cables.

Terminal connection pluggable; < 2,5 mm²

Type of connection 2 wire current sink - polarity reversal protection only
for connection to extra-low voltage according to
SELV or PELV

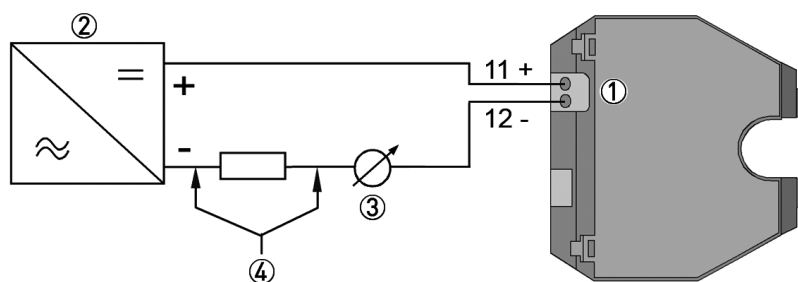

- ① Current output ESK4 /ESK4A
- ② Power supply 14...30 VDC
- ③ Measuring signal 4...20 mA
- ④ External load, HART® communication

Power supply M40 with galvanic isolation

Wiring must be planned with great care when it comes to connecting other devices such as evaluation units or process control. Internal connections in these devices (e.g. GND with PE, mass loops) may lead to non-permitted voltage potentials which could negatively affect the function of the converter itself or that of a device connected to it. In such cases a protected extra-low voltage (PELV) is recommended.

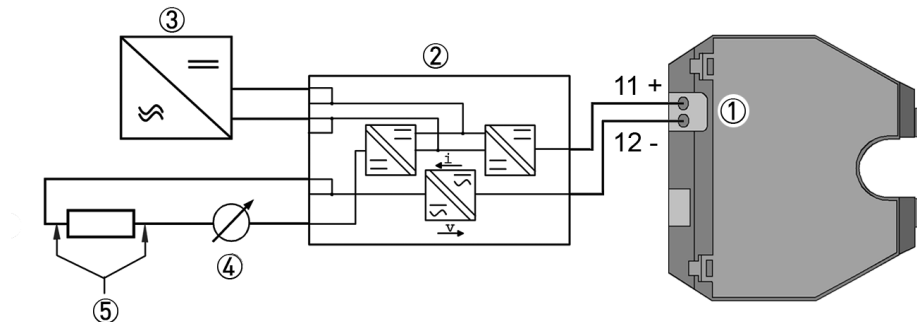

- ① Terminal connection
- ② Converter supply isolator with electrical isolation
- ③ Power supply (see supply isolator information)
- ④ Measuring signal 4...20 mA
- ⑤ External load, HART® communication

Connections at hazardous locations

Before installation in hazardous location read the Supplementary Installation and Operating Instructions - Flap-type flow meter KFS ... Ex.

Power supply

The supply voltage has to be between 14 VDC and 30 VDC. This is based on the total resistance of the measuring loop. To calculate this, the resistance of each component in the measuring loop (not including the device) must be added up.

The required supply voltage can be calculated using the formula below:

$$U_{\text{ext.}} = R_L \times 24 \text{ mA} + 14 \text{ V}$$

where

$U_{\text{ext.}}$ = the minimum supply voltage and
 R_L = the total measuring loop resistance.

The power supply has to be able to supply a minimum of 30 mA!



6.4.1 HART® communication with ESK4

HART® communication is not obligatory in order to operate the ESK4. When HART® communication is carried out with the ESK4, the analogue measured data transmission (4...20 mA) is not impaired in any way. Exception for multidrop operation. In multidrop mode, a maximum of 15 devices with HART® function can be operated in parallel, whereby their current outputs are switched inactive (I approx. 4.5 mA per device).

A load of at least 230 Ohm is required for HART® communication.

The maximum load resistance is calculated as follows:

$$R_L = (U_{\text{ext.}} - 14V) / 24 \text{ mA}$$

Use a twisted two-core cable to prevent electrical interference from impeding the DC output signal.

In some cases a shielded cable may be necessary, if noise levels higher than the NE21 specification are anticipated.

Configuration

The ESK can be configured via HART® communication. DD (Device Description) for AMS and PDM as well as a DTM (Device Type Manager) for PACTware™ are available for configuration. They are available on request.

The current flow rate can be transmitted using the integrated HART® communication. A flow counter can be configured. Two limit values can be monitored. The limit values are assigned either to flow values or to the counter overflow.



Self monitoring - Diagnostics

During both start-up and operation, a wide variety of diagnostic functions are performed cyclically in the ESK4 / ESK4A in order to guarantee function reliability. When an error is detected, a failure signal (high) is activated (current > 21 mA, typically 22 mA) via the analogue output. In addition more detailed information can be requested via HART® (CMD#48). The failure signal is not activated for information and warnings.

Diagnostic functions (Monitoring):

- Plausibility of FRAM data
- Plausibility of ROM data
- Working range of internal reference voltages
- Signal detection of the measuring range of the internal sensors
- Temperature compensation of the internal sensors
- Calibration based on the application
- Plausibility of counting value
- Plausibility of physical unit, system and selected unit

6.4.2 ESK4 - Loop Check Mode

The ESK4 is equipped with a loop check function, enabling a simple test of the entire 4...20 mA current loop.

It is activated and operated using a microswitch ①.

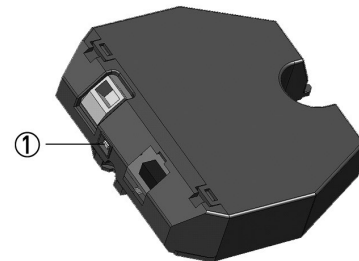

CAUTION!

When activating the loop check mode, ensure that no alarms are unintentionally triggered in the downstream system components.

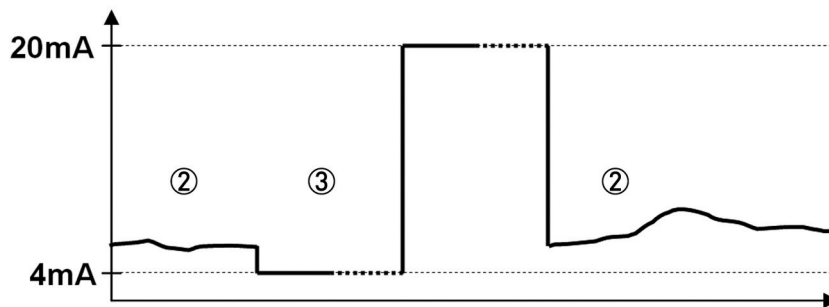

- Press and hold the microswitch ① for more than 6 seconds to activate loop check mode ③. The current output jumps to constant 4mA.
- Change the current output from constant 4 to constant 20 mA as often as you like by briefly pressing it (less than 6 seconds) to check the function of the measuring circuit.
- Exit loop check mode by holding down the microswitch (longer than 6 seconds). The current output jumps back to measuring mode ②.

INFORMATION!

If the microswitch has not been pressed for longer than 60 seconds, the ESK4 automatically reverts to measuring mode ②.

6.4.3 Technical Data EM

Terminal connection	2,5 mm ²
Power supply	14 ... 30 V DC (12 ... 30 V DC ohne EMZ)
Min. power supply for HART ®	20 V DC bei 250 Ω Bürde
Measuring signal	4 ... 20 mA für 0 - 100 % Durchflusswert
Power supply influence	< 0,1 %
External resistance dependency	< 0,1 %
Temperature influence	< 5 µA/K
Max. external resistance / load	0 (250 ¹⁾) ... 650 Ω
Ambient temperature	-40 ... +70 °C
Certification to	PTB 10 ATEX 2021 X
Inner inductance (Li) / capacitance (Ci)	10 µH/~0 nF
Switch marking	II 2G Ex ia IIC T6 Gb (max. Ui = 30 V, Ii = 100 mA, Pi = 1 W)

¹⁾ With HART™-communication, these are minimum values.

Please note when used in hazardous areas: The installed equipment may only be connected to separate intrinsically safe circuits.



6.5 Plug-in contact unit IK1, IK2, IKS1, IKS2

INFO:

KFS-M40-IK/IKS and
KFS-EM may be combined!

Indicator M40:

- ① contact unit IK/IKS
- ② EM current output
4 ... 20 mA

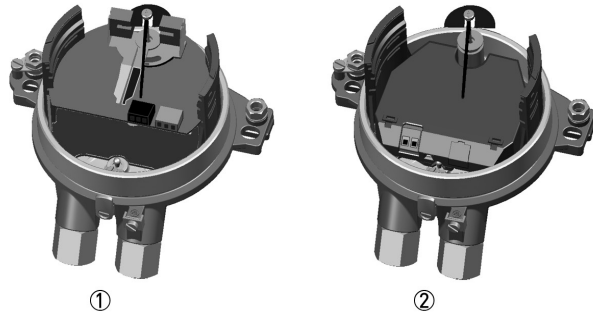

The flap-type flow meter KFS can be equipped with a maximum of two inductive limit value switches. The switch operates with a slot type initiator which is actuated inductively by the half-round metal vane on the measuring pointer. The switching points are set by means of a contact pointer, the position of the contact pointer at the same time serving to visually indicate the set limit value.

Switch types:

SC3,5-N0-Y 2-wire-technology
(NAMUR)

SB3.5-E2 3-wire-technology

- ① MIN. Limit value switch
- ② MAX. Limit value switch
- ③ locking screw
- ④ contact pointer
- ⑤ terminal socket

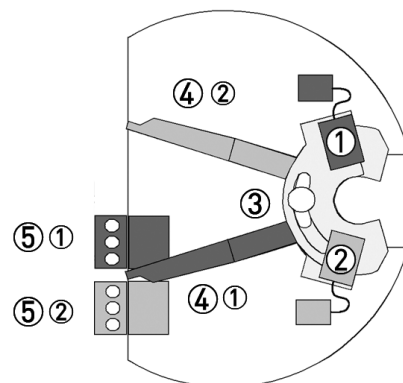

6.5.1 Electrical connection

Remove the housing cover of the indicator part to connect the plug-in contact unit. The terminals ⑤ are of the plug-in type and can be detached for connecting the cables.

The built-in contact types are specified on the indicator nameplate.

SC3,5-N0-Y limit contacts in 2-wire technology are connected in conformity with NAMUR.

SB3.5-E2 limit contacts in 3-wire technology require a supply power of 10 ... 30 VDC. They can be connected direct to a PLC control system.

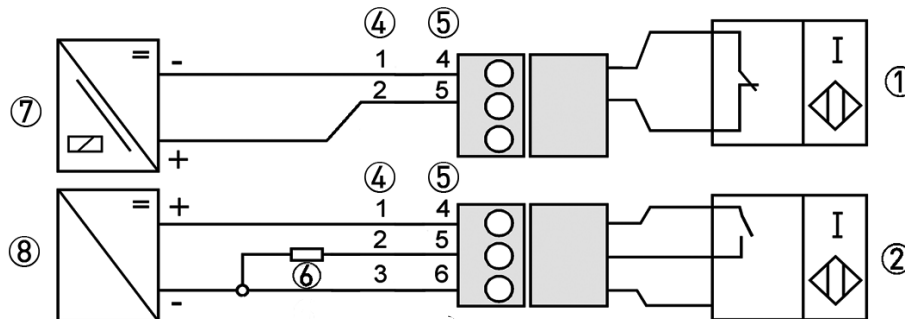

- ① 2-wire limit switch SC3,5-NO-Y NAMUR
- ② 3-wire limit switch SB3,5-E2
- ④ Terminal connection MIN contact
- ⑤ Terminal connection MAX contact
- ⑥ 3-wire load
- ⑦ NAMUR isolated switching amplifier
- ⑧ 3-wire power supply

Electrical connection of limit contact in 2-wire technology
Terminal assignment for SC3,5-NO-Y

Contact	MIN			MAX		
Plug colour	black			gray		
Labelling	1	2	3	4	5	6
2-wire technology	-	+	X	-	+	X

Electrical connection of limit contact in 3-wire technology
Terminal assignment for SB3,5-E2

Contact	MIN			MAX		
Plug colour	black			gray		
Labelling	1	2	3	4	5	6
3-wire technology	+	∩	-	+	∩	X



6.5.2 Setting the limit value

Setting is made directly via the contact pointers ① and ②:

1. Unscrew housing cover.
2. Move scale to the side.
3. Slightly loosen locking screw ③.
4. Slide scale back up to point where it snaps into place.
5. Set contact pointers ① & ② to the desired switching point.
6. After setting, the pointer should be tightened down again with locking screw ③.
7. Replace housing cover and screw down.

scale opening

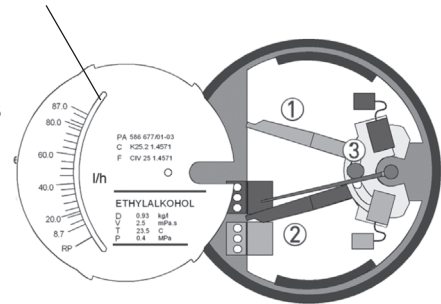

6.5.3 Switching contact definition

An alarm is generated when the pointer vane ③ dips into the slot. When the pointer vane is outside the slot type initiator, a wire break will also cause an alarm to be initiated.

- ① MIN – Contact
- ② MAX – Contact (optional)
- ③ pointer and pointer vane

NOTE:

- No wire break identified by SB3,5-E2!
- Maximum contact type
In the alarm status the vane is located outside the slot. Wire break identification is not available in this case.

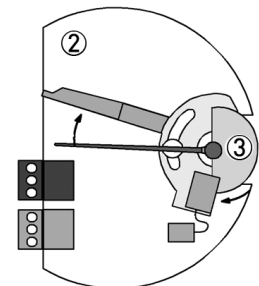
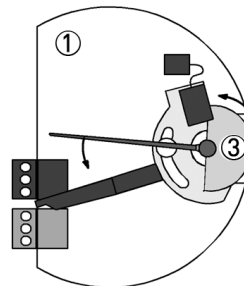

In the IK2 / IKS2 version, both contact systems are equipped

6.5.4 Definition MINMIN - MAXMAX

- ① MIN 2 Contact or MAX 1 Contact
- ② MIN 1 Contact or MAX 2 Contact

Current consumption in the shown position

Contact	Type	Current
MIN 1	NAMUR	≤ 1 mA
MIN 2	NAMUR	≤ 1 mA
MAX 1	NAMUR	≥ 3 mA
MAX 2	NAMUR	≥ 3 mA

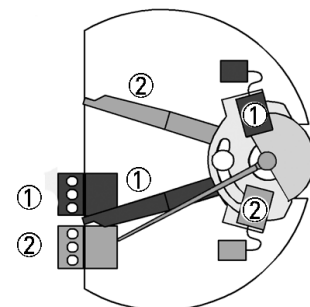



6.5.5 Technical Data

2-wire SC3,5-N0-Y	KFS-...-IK1/2
Switching element	NAMUR NC
Nominal voltage U_0	8 V
Current consumption:	
Pointer vane not sensed	≥ 3 mA
Pointer vane sensed	≤ 1 mA
Ambient temperature	-25 ... +100 °C
EMV according	NE21
SIL according	IEC 61508
Ex-approval	PTB 99 ATEX 2219X only with intrinsically safe isolating switch amplifier
3-wire SB3,5-E2	KFS-...-IKS1/2
Switching element	PNP NO
Nominal voltage U_0	10 ... 30 V DC
Current consumption:	
Pointer vane not sensed	$\leq 0,3$ V DC
Pointer vane sensed	$U_B = -3$ V DC
Ambient temperature	-25 ... +70 °C
Continuous current	max. 100 mA
Idle Current I_0	≤ 15 mA
EMV accprding	EN 60947-5-2

6.5.6 Electrical data hazardous area

Contact Type	Labelling data				
	U_i [V]	I_i [mA]	P_i [mW]*	C_i [nF]	L_i [uH]
SC3,5-N0-Y...	≤ 16	≤ 25	≤ 64	≤ 150	≤ 150
I7S23,5-N	≤ 16	≤ 52	≤ 169	≤ 150	≤ 150
SJ3,5-SN	≤ 16	≤ 25	≤ 64	≤ 30	≤ 100
SJ3,5-S1N	≤ 16	≤ 52	≤ 169	≤ 30	≤ 100

* depending on the used isolating switch amplifier

Operation of the SC3,5-N0-Y contact requires the use of an isolating switch amplifier, e.g. Pepperl + Fuchs Series KF .. -SR2



6.6 Replacement - Retrofitting an ESK4 and its calibration

Retrofitting is only possible if the display was delivered "with EM preparation".

When replacing or retrofitting an ESK4 the serial number must be specified when ordering. This information is given on the labelling of the display.

The ESK4 is factory calibrated so that, for example, replacement or retrofitting can be done without recalibration.

Required components (see sect. 6.9):

- ESK4 Sensor Module
- Connectors 11/12

Removing ESK4:

1. Cut off ESK4 power supply.
2. Lift up the ESK4 with a screwdriver and pull it out.

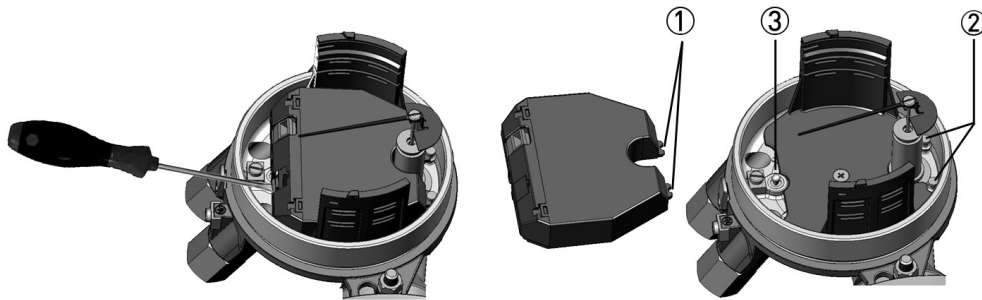

Installation ESK4:

1. The two fixing lugs ① of the ESK4 are inserted under the two bolts ② of the baseplate.
2. The ESK4 is pushed with some pressure on the spring bolt ③ until it locks and secured the ESK4 safely.
3. As last the connector 11/12 is inserted

Desired changes of the measuring range, medium temperature, medium, density, viscosity or pressure is desired can be carried out at **Kirchner und Tochter**.



6.7 Retrofitting a second limit value switch

The retrofit kit consists of the required contact pointer and integrated contact. The connecting cable is fitted with the integrally moulded plug.

1. Unplug the contact unit from the module rack.
2. Remove locking screw ①.

 **Caution:**
Spring ② is under pressure

3. Assemble contact pointers ④, slide rings ③, spring ② and locking screw as shown in the drawing.
4. The second ring ③ is already provided in the version with one contact.
5. Insert plug connector of the contact (blue) into the socket on the circuit board.
6. Plug in and connect up the contact unit.

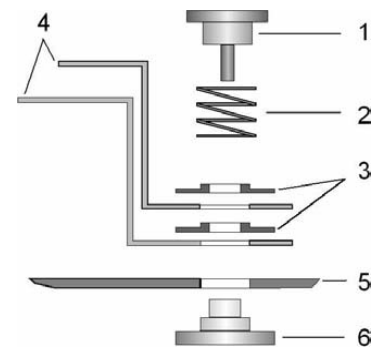

6.8 Flow Totalizer KFS-EMZ

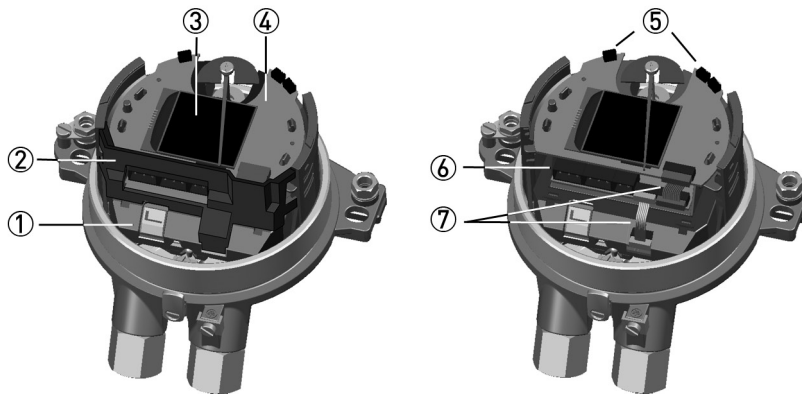

- ① ESK4 connection
- ② Module cover
- ③ Display
- ④ Display module ESK4-IO
- ⑤ Operating keys ↵ ↑
- ⑥ Connection binary outputs and reset input
- ⑦ Module connection cable



The flow totalizer ESK4-T (EMZ) is the combination of the analogue current output ESK4 (EM) and the display module ESK4-IO. Both modules are installed together in the M40 display part, the ESK4-IO can only be used together with the ESK4.

An LC display indicates the measured value with units resp. the meter count with units. Counter reading max. 11-digit with power failure proof storage. Binary flags indicate the limit value status and a 0 ... 100% bar graph displays the measured value. Furthermore NE107 diagnostics status symbols are displayed and the configuration menu is carried out in plain text.

There are two configurable binary outputs for switch or pulse output and a binary input for start / stop or reset the counter. The power and data connection between ESK4 and ESK4-IO is provided by a flat ribbon cable.

The flow totalizer is factory set according to the order data and does not need to be adjusted! The conversion factor of the counter is adjusted unless otherwise ordered based on the measurement range, so that the total value (in liters, m³, etc.) can be read directly.

Further information on commissioning and operation, refer to the supplementary installation and operating instructions EMZ which is supplied your KFS-EMZ.



6.9 Component overview for electrical Retrofit

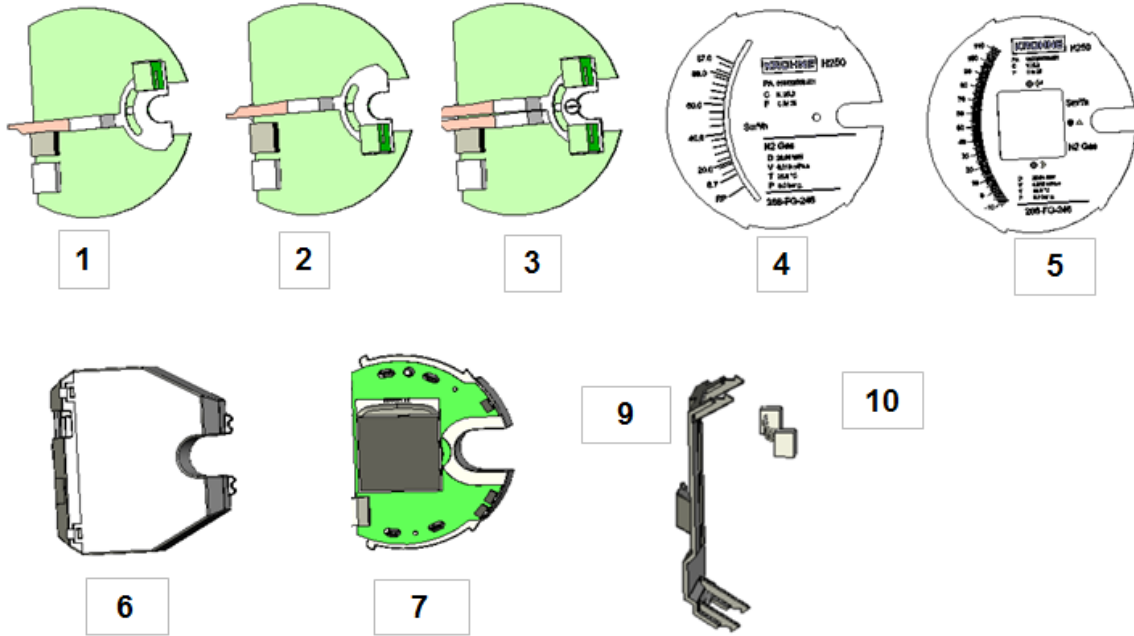

ESK4	11; 12		12
ESK4-I/O	1,2,3; 4,5,6; 7,8		13

1. Limit switch board IK1/IKS1 MIN
2. Limit switch board IK1/IKS1 MAX
3. Limit switch board IK2/IKS2 MINMAX
4. Standard scale
5. Scale with cutout for LC-Display (ESK4-T)
6. Sensor module ESK4 (4...20 mA)
7. ESK4 I/O LCD module
9. Cover for ESK4-T
10. Ribbon cable between modules for ESK4-T
12. Terminal connector for ESK4: 11/12 for 4 ... 20mA/HART
13. Terminal connectors for I/O-LCD module: 1/2/3 for binary output B1, 4/5/6 for binary output B2, 7/8 for binary input B3



7 Service

All devices with defects or deficiencies should be sent directly to our repair department. In the service area of the Kirchner und Tochter homepage (www.kt-flow.de) you will find the declaration of decontamination as download and more information about returns.

To avoid risks to our employees and the environment, we can only process devices, for which we get a declaration of decontamination certifying that they are safe due to legal regulations. For questions, please contact our sales department, Tel. +49 2065-96090.

8 Disposal

Please help to protect our environment and dispose workpieces in conformity with current regulations resp. continue using them.

9 Remaining risks

A risk analysis in accordance with the pressure equipment directive has been carried out for the devices. The residual risk is described as follows:

- The devices are designed according to the valid and applicable rules and standards for static operation and their pressure resistance is tested for the declared maximum pressure and temperature (no tests for cyclical change).
- Responsibility for the use of the measuring devices with regard to corrosion resistance of the used materials against the measured fluid lies solely with the operator.
- Avoid abrasion.
- Avoid pulsation and cavitation.
- Protect devices from vibration and high-frequency oscillation.
- Due to the spring chamber being at a right angle to the measuring line, draining (backflow) may be delayed.
- Implement appropriate measures to counteract external fire hazards



10 Technical Data

10.1 General technical data

Measuring accuracy	5 % FS
Scale	in physical units, e.g.: l/h, m³/h
Length of scale	max. 95 mm
Measuring range	min. 1:10
Degree of protection, indicator part	Standard: IP66; M40: IP68 (KFS-M40)
Corrosion protection for steel version	epoxy paint, kiln-dried, traffic blue (RAL 5017), satin finished
Corrosion class	C2
Mounting length	50 mm (standard) 60 mm (¹ PVC/PP/PVDF & DN 250 - 300)
Connections	mounting between flanges acc. to DIN EN 1092-1, PN 6/10/16/25/40
optionally	mounting between flanges acc. to ASME B16.5, JIS B 2220, others on request



10.2 Materials

Material, ring	Wetted internals	Wetted gasket ²⁾
S355	1.4571	Sil 4400
1.4571	1.4571	Sil 8800
PVC	1.4571 ¹⁾	EPDM
PP	1.4571 ¹⁾	EPDM
PVDF	1.4571 ¹⁾	FKM
Indicator part	KFS	KFS-M40
scale casing	stainless steel 1.4301	aluminium painted
pointer	aluminium painted	aluminium painted
scale	aluminium coated	aluminium coated
screen	PC, optionally glass	float glass

¹⁾ optionally Hastelloy C4

²⁾ others on request

Rubber coating on request

Material	DN [mm]			Media temperature [°C]			Pressure resistance [bar] ²⁾						
S355/1.4571	25	-	300	-70	-	200	6/10/16/25/40						
				-20	-	70 ¹⁾							
PVC	25	-	80	0	-	20	10						
							100	-	300	0	-	40	6
													25
PP	25	-	80	0	-	20	10						
							100	-	300	0	-	80	6
													25
PVDF	25	-	80	-40	-	20	10						
							100	-	300	-40	-	140	6
													25

The process liquid must not freeze.

¹⁾ KFS ... Ex: Where insulation measures have been carried out, -70 ... +200 °C are also possible.

²⁾ optionally: PN 16, 25 or 40



10.3 Measuring ranges H₂O

DN	Standard measuring ranges [m ³ /h] H ₂ O at 20 °C					
25	0,5 - 7	1 - 12				
32	0,5 - 8	1,8 - 18	3 - 30			
40	0,6 - 6	1 - 10	2 - 20	3 - 30	5 - 50	
50	0,8 - 8	2 - 20	3 - 35	5 - 50	7 - 70	
65	2 - 20	4 - 40	6 - 60	9 - 90	11 - 110	
80	2 - 20	4 - 40	6 - 60	10 - 100	12 - 120	20 - 200
100	4 - 40	8 - 80	12 - 120	16 - 160	20 - 200	25 - 250
125	5 - 55	8 - 80	12 - 120	14 - 140	20 - 200	35 - 350
150	6 - 60	10 - 100	14 - 140	18 - 180	22 - 220	35 - 350
200	5 - 50	9 - 90	12 - 120	15 - 150	20 - 200	25 - 250
250	18 - 180	25 - 250	30 - 300	40 - 400		
300	15 - 170	20 - 220	25 - 250	30 - 300	50 - 500	

DN	Special measuring ranges [m ³ /h] H ₂ O at 20 °C			
200	40 - 400	60 - 600		
250	50 - 500	60 - 600		
300	60 - 650	90 - 900		
350	50 - 500	70 - 700	90 - 900	100 - 1000
400	60 - 600	75 - 750	110 - 1100	400 - 1850
500	70 - 700	100 - 1000	135 - 1350	200 - 1600
600	80 - 800	125 - 1250	165 - 1650	

intermediate measuring ranges possible

The measuring ranges for the series KFS-EM differ slightly from the above values. More detailed information and measuring ranges for other media and operating conditions are available on request.



KFS

Flap-type flow meters

10.4 Measuring ranges air

DN	Standard measuring ranges [m ³ /h] air at STP ¹⁾	
	minimum range	maximum range
25	15 - 150	30 - 400
32	15 - 150	30 - 400
40	15 - 150	45 - 450
50	18 - 180	75 - 750
65	18 - 180	80 - 800
80	20 - 200	100 - 1000
100	25 - 250	220 - 2200
125	25 - 250	360 - 3000
150	30 - 300	300 - 3000
200	40 - 400	300 - 3000
250	100 - 1000	400 - 4000
300	120 - 1200	500 - 5000

¹⁾ at STP: at standard conditions (0 °C and 1013 mbar abs.)

intermediate measuring ranges possible

The measuring ranges for the series KFS-EM differ slightly from the above values. More detailed information and measuring ranges for other media and operating conditions are available on request.

10.5 Dimensions and weights

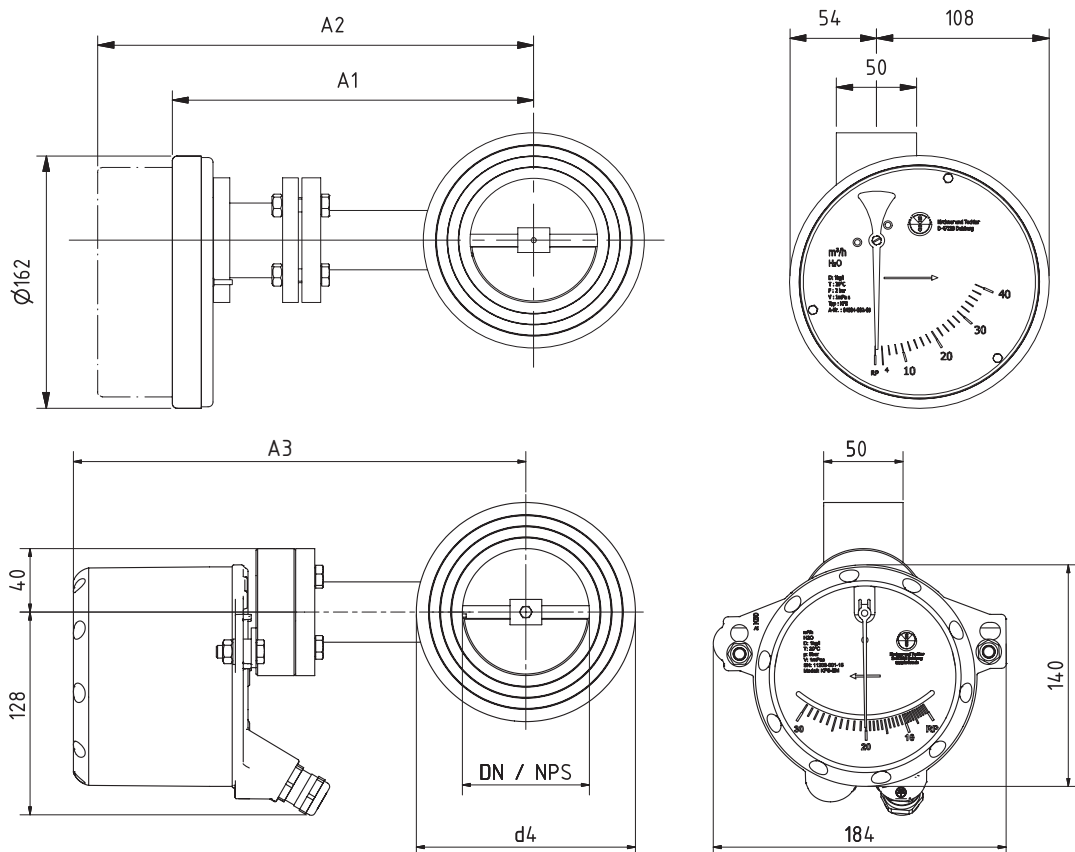



DN	d ₄	Weight [kg]		ASME flange connection		KFS		KFS-IK		KFS-EM *)	
		Steel	PVC	NPS ³⁾	d ₄	A1 ²⁾	A1 ²⁾ (ASME)	A2 ²⁾	A3 ²⁾ (ASME)	A3 ²⁾	A3 ²⁾ (ASME)
25	68	3,8	2,0	1"	51	202	199	249	246	233	233
32	78	3,8	2,0	1¼"	64	206	204	253	251	236	238
40	88	3,8	2,0	1½"	73	206	206	253	253	242	240
50	102	3,9	2,1	2"	92	211	212	258	259	247	246
65	122	5,0	2,3	2½"	105	219	217	266	264	253	251
80	138	5,6	2,5	3"	127	226	225	273	272	260	259
100	158	6,4	2,7	4"	157	236	237	283	284	270	271
125	188	8,0	2,8	5"	186	249	250	296	297	283	284
150	212	8,8	3,3	6"	216	261	263	308	310	295	297
200	268	11,4	3,7	8"	270	286	287	333	334	320	321
250	320	13,0	4,5	10"	324	311	313	358	360	345	347
300	370	22,0	4,9	12"	381	336	338	383	385	370	372
350	430	29,3	–	–	–	376	–	423	–	395	–
400	482	31,5	–	–	–	401	–	448	–	420	–
500	585	39,0	–	–	–	451	–	498	–	485	–
600	685	45,5	–	–	–	501	–	548	–	535	–

all dimensions in mm except NPS

¹⁾ PVC/PP/PVDF versions max. DN 250 - 300 installation length 60mm.

²⁾ PVC/PP/PVDF versions differ minimally from the standard.

³⁾ NPS = Nominal pipe size acc. to ANSI / ASTM

Note:

The flap axis for DN32 and DN25 devices is located 9mm above the ring axis!



10.6 M12 Right angle plug

M12 x 1 Right angle plug	
Connector	field-wireable female connector, M12 x 1, angled
Number of poles	4-pole, A-coding
Contacts	metal, CuZn, optalloy-plated
Contact carriers	plastic, PA, black
Grip	plastic, PBT, black
Seal	plastic, FKM
Degree of protection	IP67 only tightened with screws
External diameter of the cable	4 ... 6 mm
Core cross-section/ Clamping ability	max. 0,75 mm ²
Screw-in thread	PG 7
Connection mode	screw clamp
Mechanical lifespan	min. 50 contact durability
Pollution degree	3
Rated voltage	max. 250 V
Insulation resistance	≥ 108 Ω
Ampacity	4 A
Forward resistance	≤ 8 mΩ
Ambient temperature	-25 ... +85 °C
Connector	

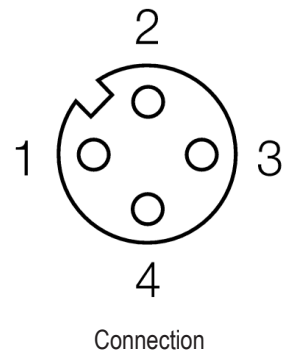
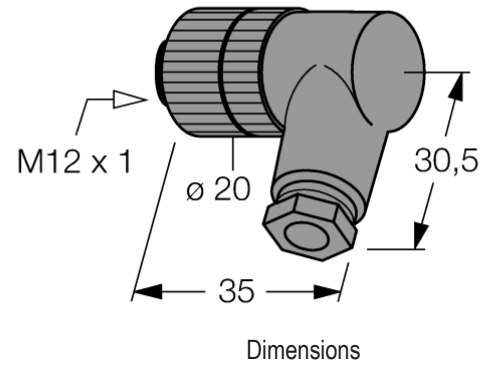



11 Spare parts, accessories

11.1 KFS with standard indicator part and limit value switches

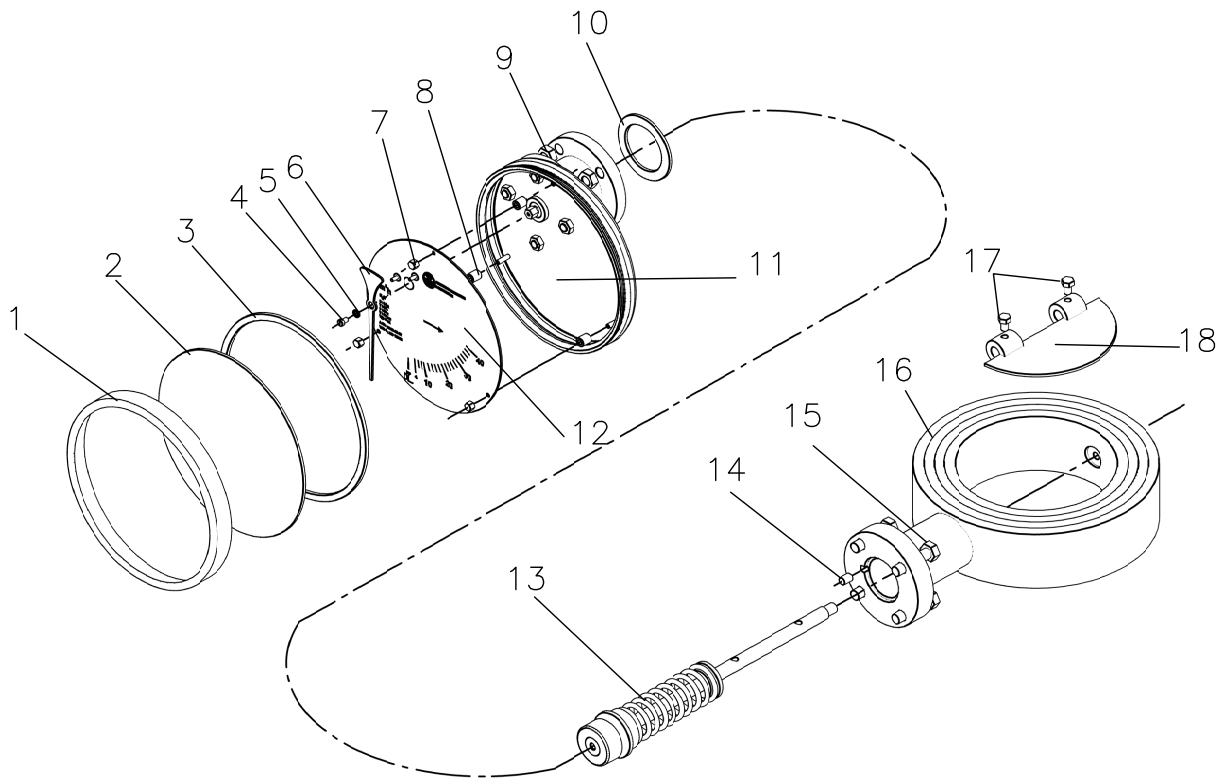



KFS

Flap-type flow meters

KFS with standard indicator part

Note:



In the explosion-proof versions a grounding cable for connection to the potential equalization system is placed on the back of the indicator part (not shown here).

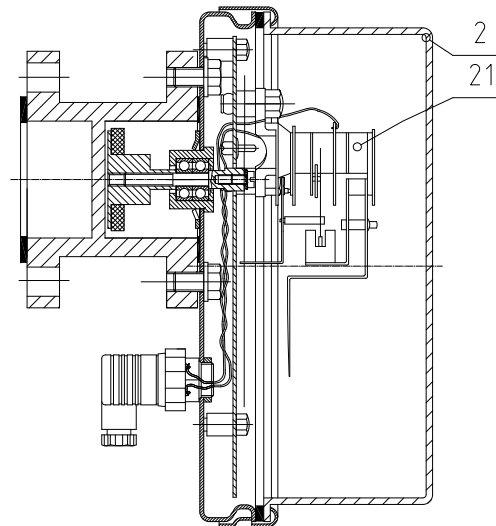
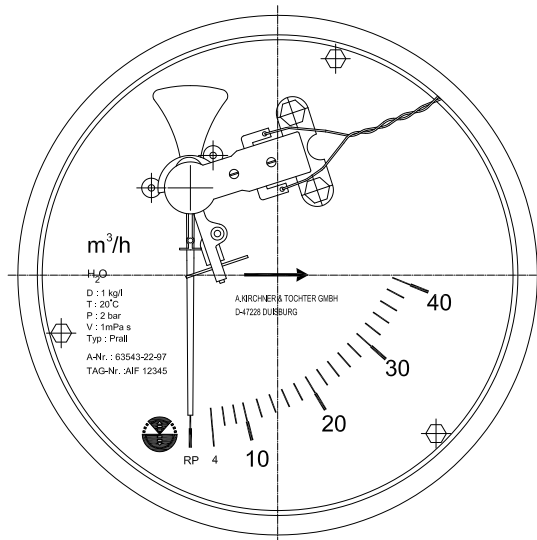

Indicator part KFS-IK1, KFS-IK2, KFS-IKS1, KFS-IKS2, KFS-RK1, KFS-RK2

Item	Qty	Description
1	1	Bayonet ring
2	1	Makrolon (polycarbonate) cover
3	1	Sealing ring
4	1	Screw M3
5	1	Spring washer
6	1	Pointer
7	3	Cap nut M3
8	3	Separator
9	4	Nut M8
10	1	Gasket
11	1	Bayonet casing

Item	Qty	Description
12	1	Scale
13	1	Spindle with magnet and spring
14	1	Alignment pin
15	4	Screw M8
16	1	Ring
17	1-2	Screws
18	1	Flap
19	8	Tooth lock washer DIN 6797-A8.4-A2 (only ATEX version, not depicted)
20		Sticker for ATEX version: reference to electrostatic charges (only ATEX vers., not depicted)
21		Contact of device used: RK/IK/IKS ...



11.2 KFS-EM

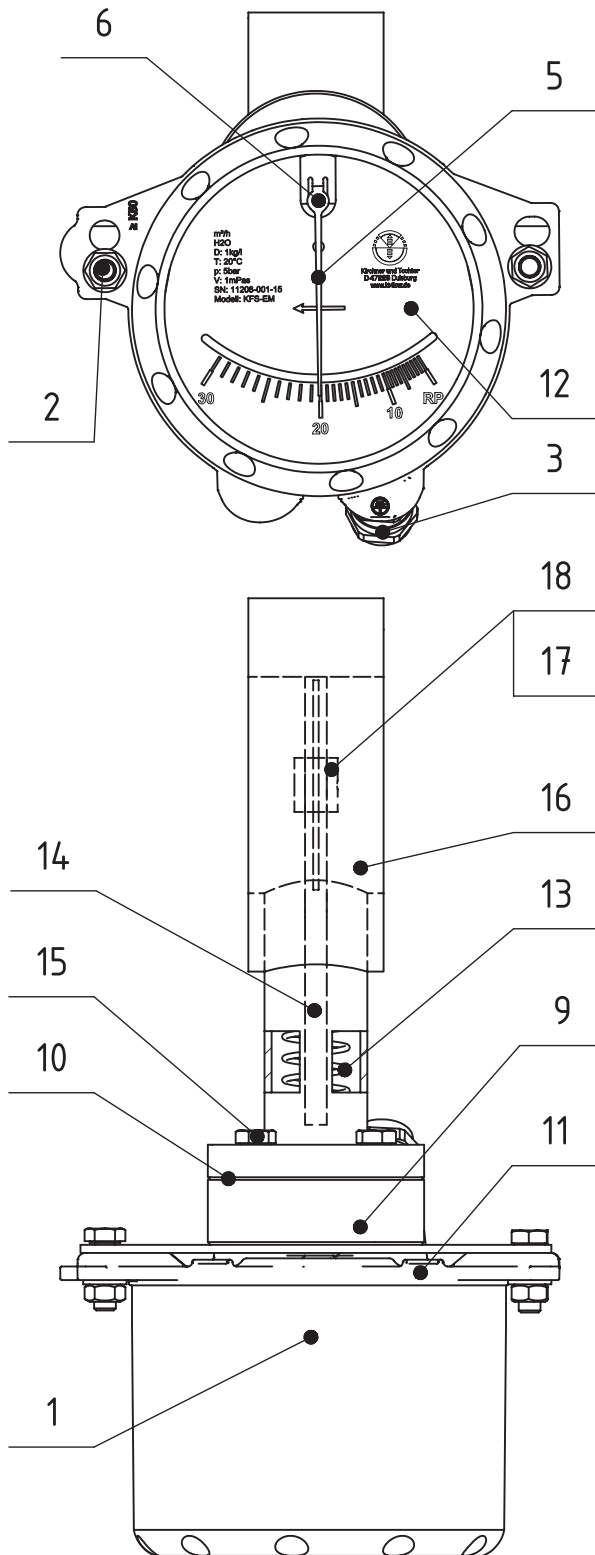

Item	Qty	Description
1	1	housing cover
2	4	hexagon screw
5	1	pointer
6	1	pointer shaft
9	1	magnet housing
10	1	gasket
11	1	rear wall
12	1	scale with nameplate
13	1	feather
14	1	wave
15	4	hexagon screw M8
16	1	ring
17	1-2	screws (flap)
18	1	flap

Note:

In the explosion-proof versions a grounding cable for connection to the potential equalization system is placed on the back of the indicator part (not shown here).

Note: To remove the indicator part from pressurized measuring unit: Loosen the screws at pos. 2



11.3 Assembly aid KFS-M40/EM (optional)

The special design of the assembly aid prevents excessive torque when tightening the M40 housing cover. Tightening and loosening gets safer and easier.

The installation aid is available on request.

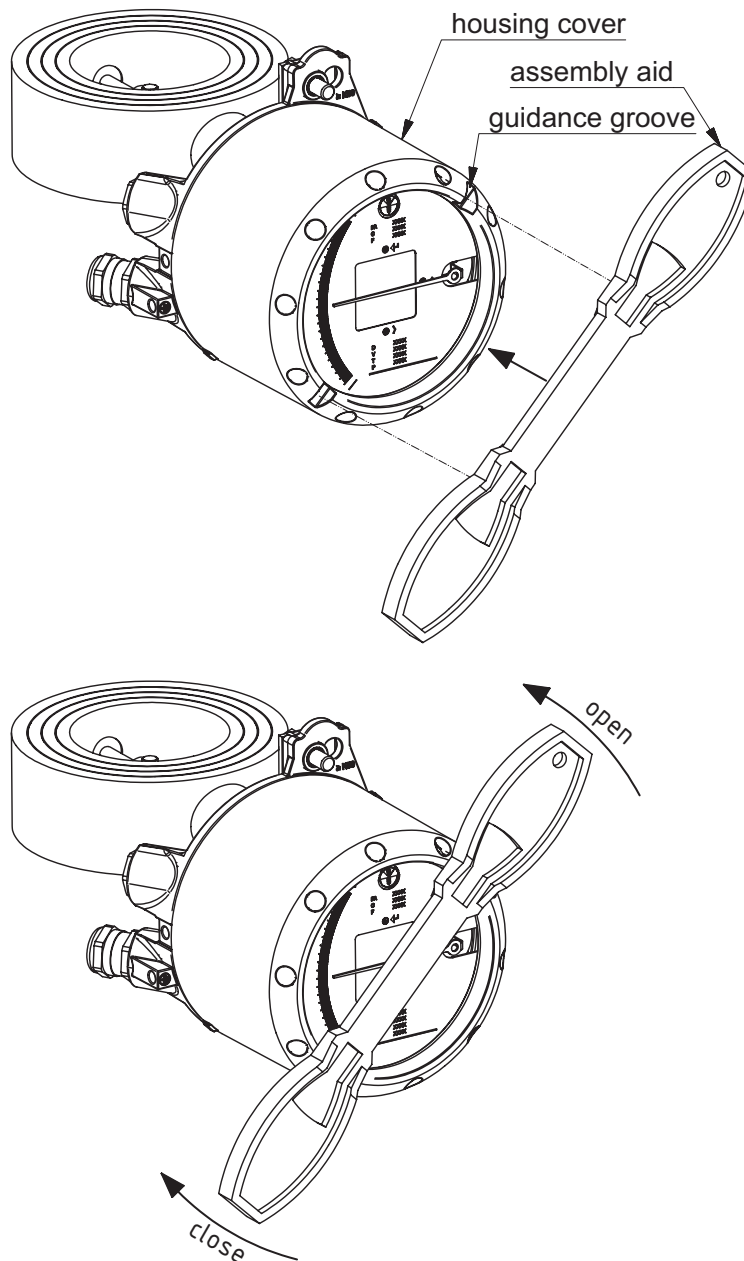



Kirchner und Tochter
Durchflussmesstechnik seit 1951



The devices from **Kirchner und Tochter** have been tested in compliance with applicable EC/EU CE-regulations of the European Community.

The respective declaration of conformity is available on request. Subject to change without notice. The current valid version of our documents can be found at www.kt-flow.de.

The **Kirchner und Tochter** QM-System is certified in accordance with DIN EN ISO 9001:2015. The quality is systematically adapted to the continuously increasing demands.